

P 170 T SMART
FAST AND SAFE
OPERATION WITH
MAXIMUM REDUCTION
IN STABILISATION
DIMENSIONS

LIFETIME EXCELLENCE



TECHNICAL SPECIFICATIONS

Max. working height	16.8 m
Max. basket bottom height	14.8 m
Max. outreach	10.6 m
Angle of main boom	-25° a + 80°
Turntable rotation	370°
Basket rotation	2 x 90°
Basket load	250 kg
Size of basket	1.4 x 0.85 x 1.1 m
Height in transport position	2.89 m
Width in transport position	2.1 m
Length in transport position	6.05 m
GVW	3500 kg

OPTIONAL

Fiberglass basket
Electric pump for internal use
Working adjustable light 60 W on the basket
Title alarm with audio signal
Insulation 1000 V
12 V electric pump
Aluminium side panels
Customised paintwork boom

WORKING DIAGRAMS

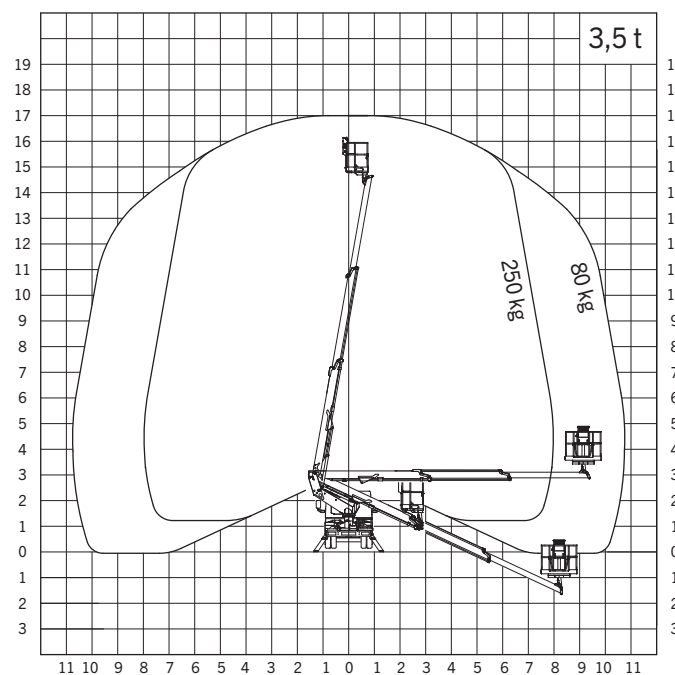

DIMENSIONS

